

MULTITEL MT 222 EX - Iveco Daily 35S14H Euro6D

Ingombro veicolo

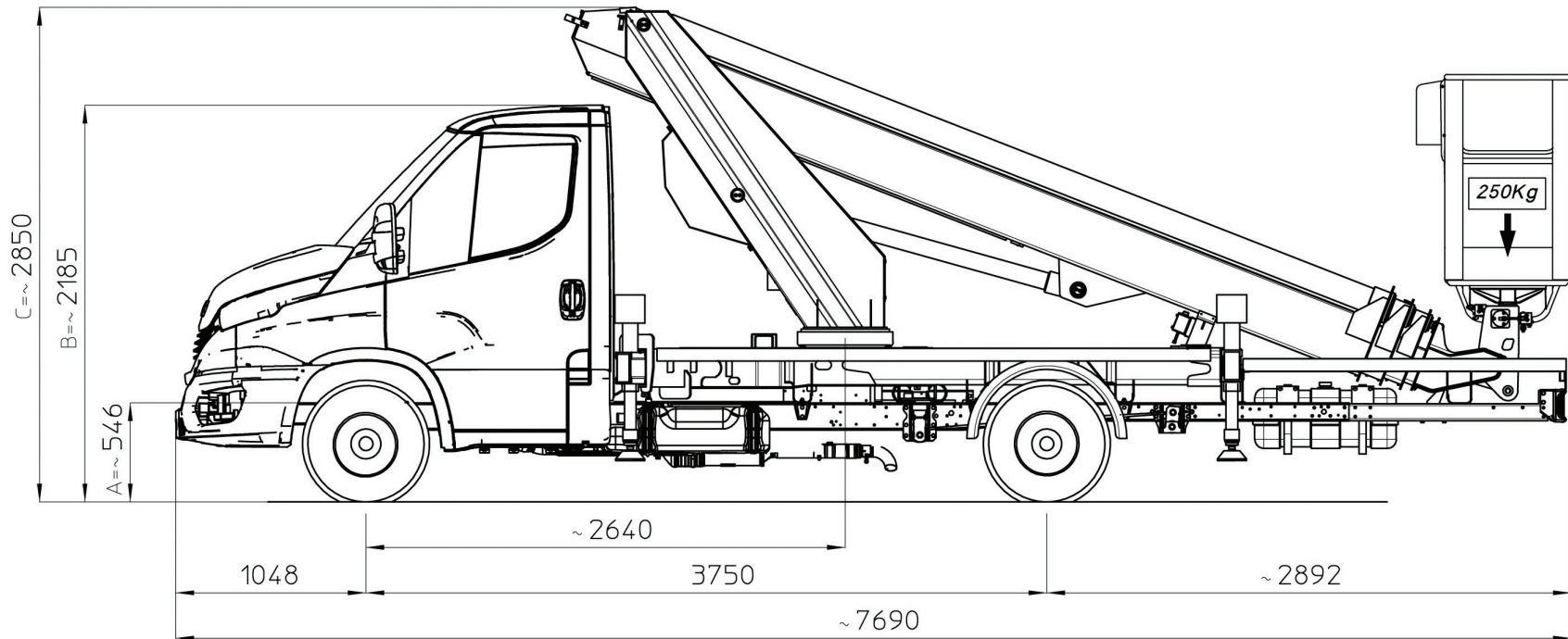

MULTITEL MT 222 EX

Ingombro stabilizzazione

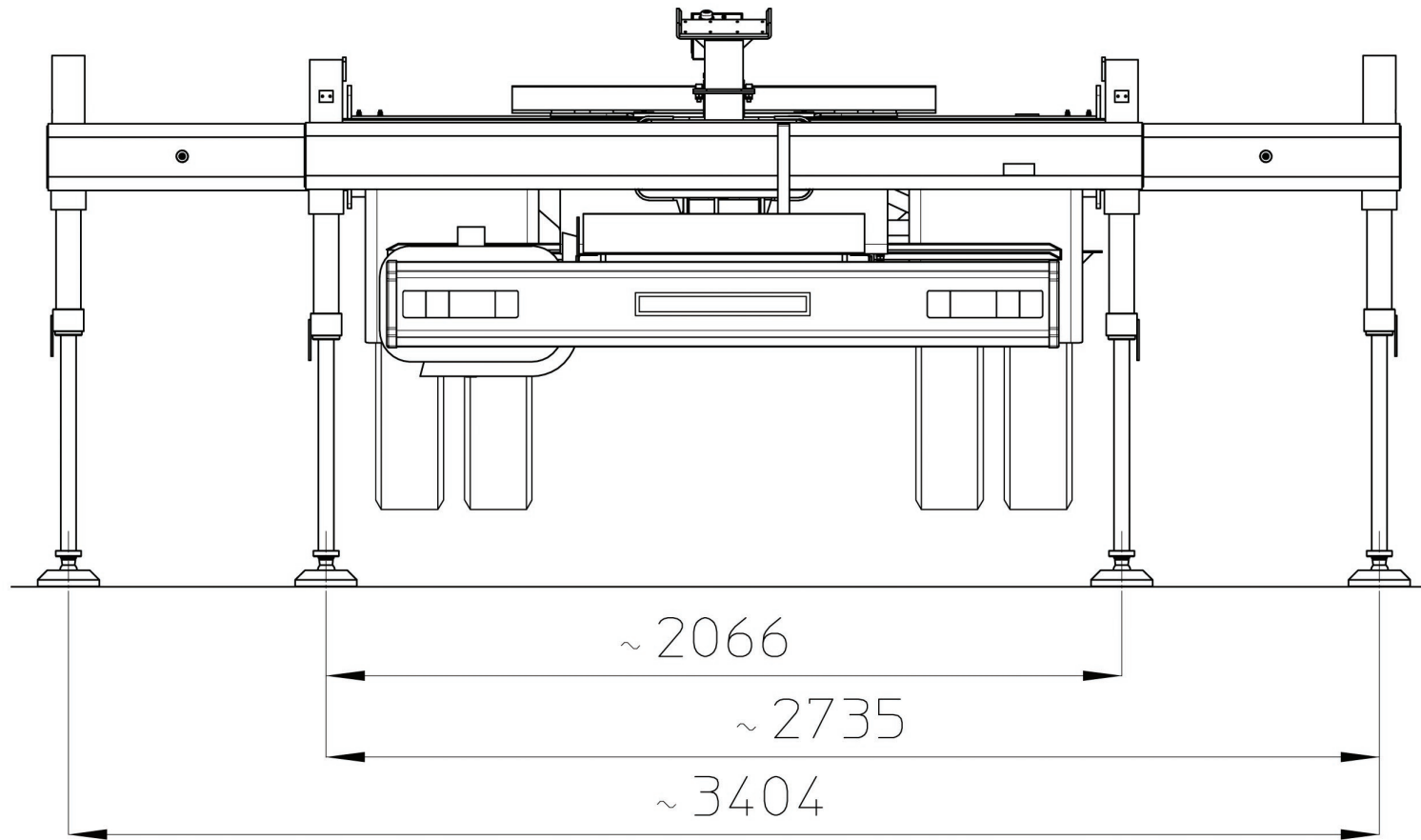

MULTITEL MT 222 EX

250 kg

80 kg

Sbraccio di lavoro, completamente estesi

8.8 m $\pm 5\%$ 12.3 m $\pm 5\%$

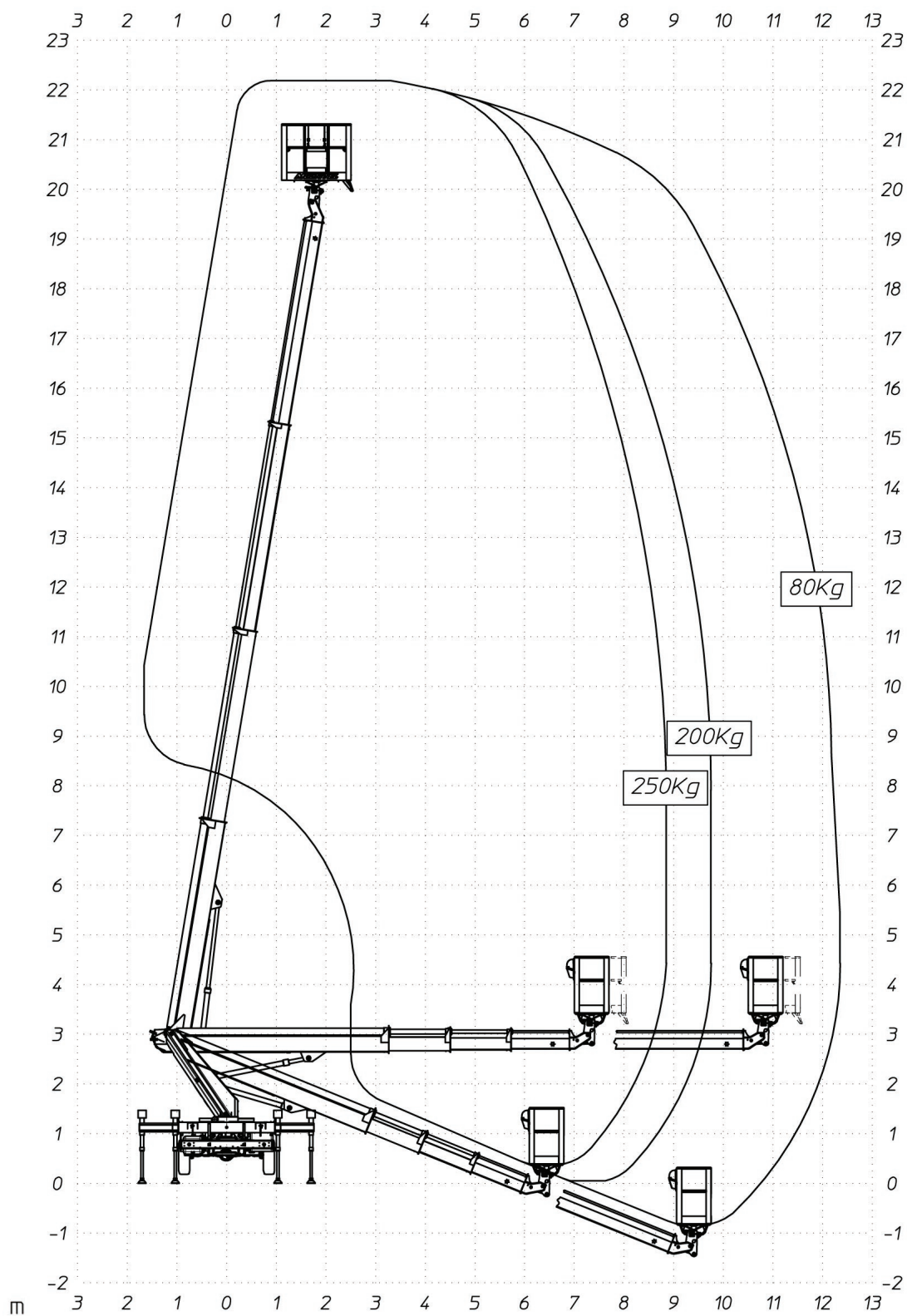

MULTITEL MT 222 EX

250 kg

80 kg

Sbraccio di lavoro, stabilizzatori in sagoma 6.6 m $\pm 5\%$ 9.5 m $\pm 5\%$

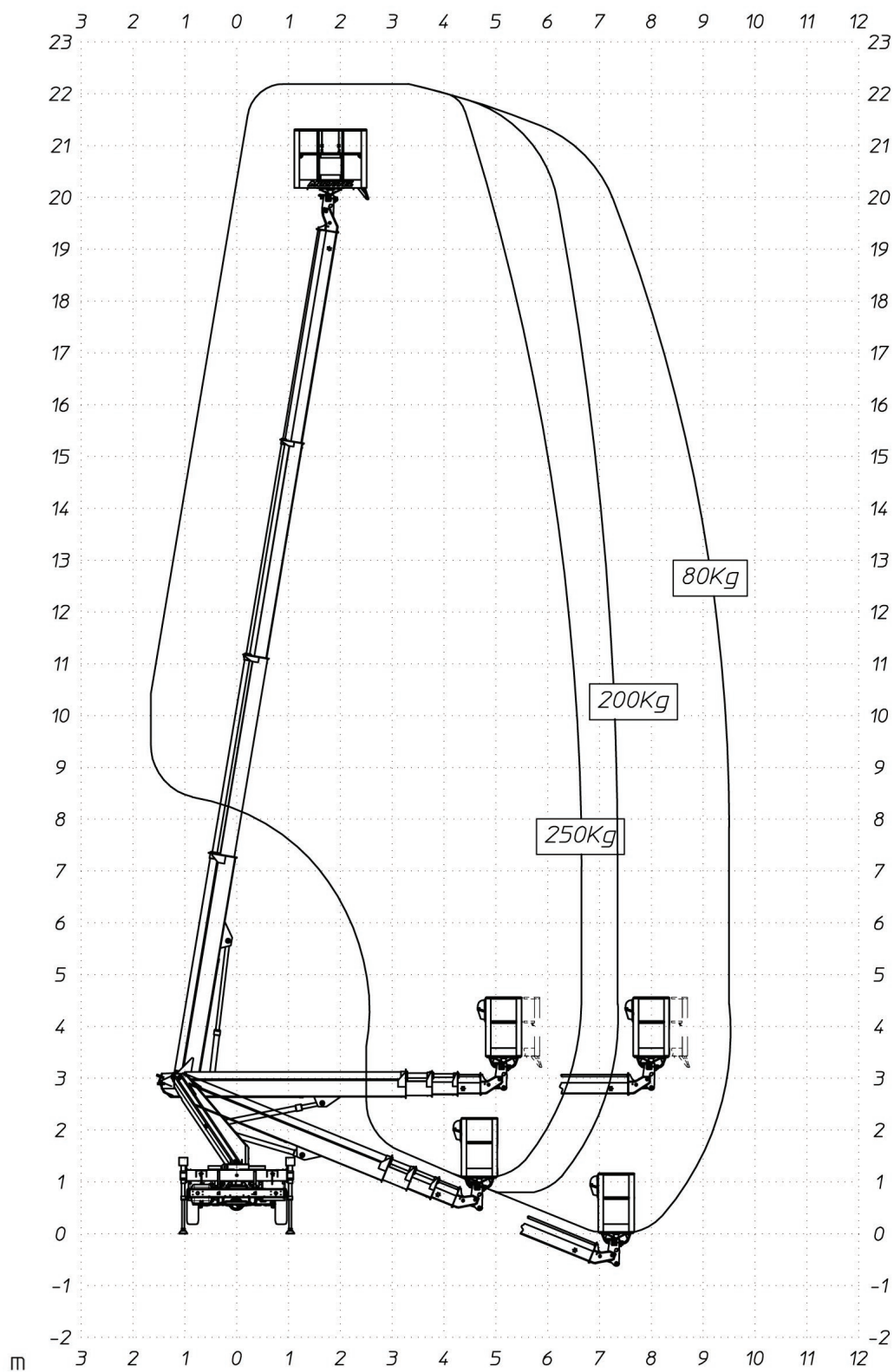

MULTITEL MT 222 EX

Ingombro stabilizzazione

