

MULTITEL MT 182 EX

200Kg

80Kg

Sbraccio di lavoro, stabilizzazione completa

10.2 m

13.3m $\pm 5\%$

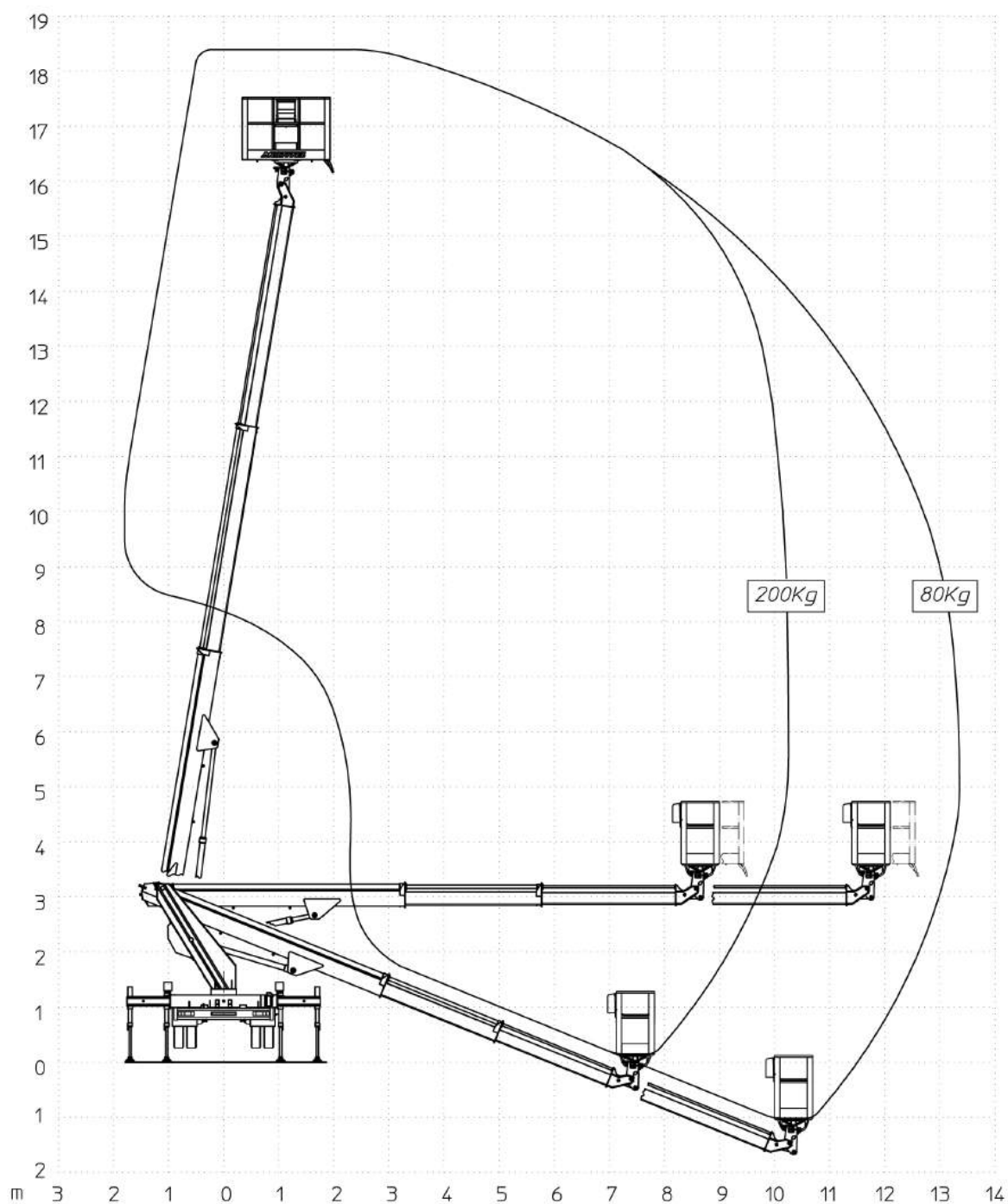

MULTITEL MT 182 EX

200Kg

80Kg

Sbraccio di lavoro, stabilizzazione minima

7.7 m

10.1m $\pm 5\%$

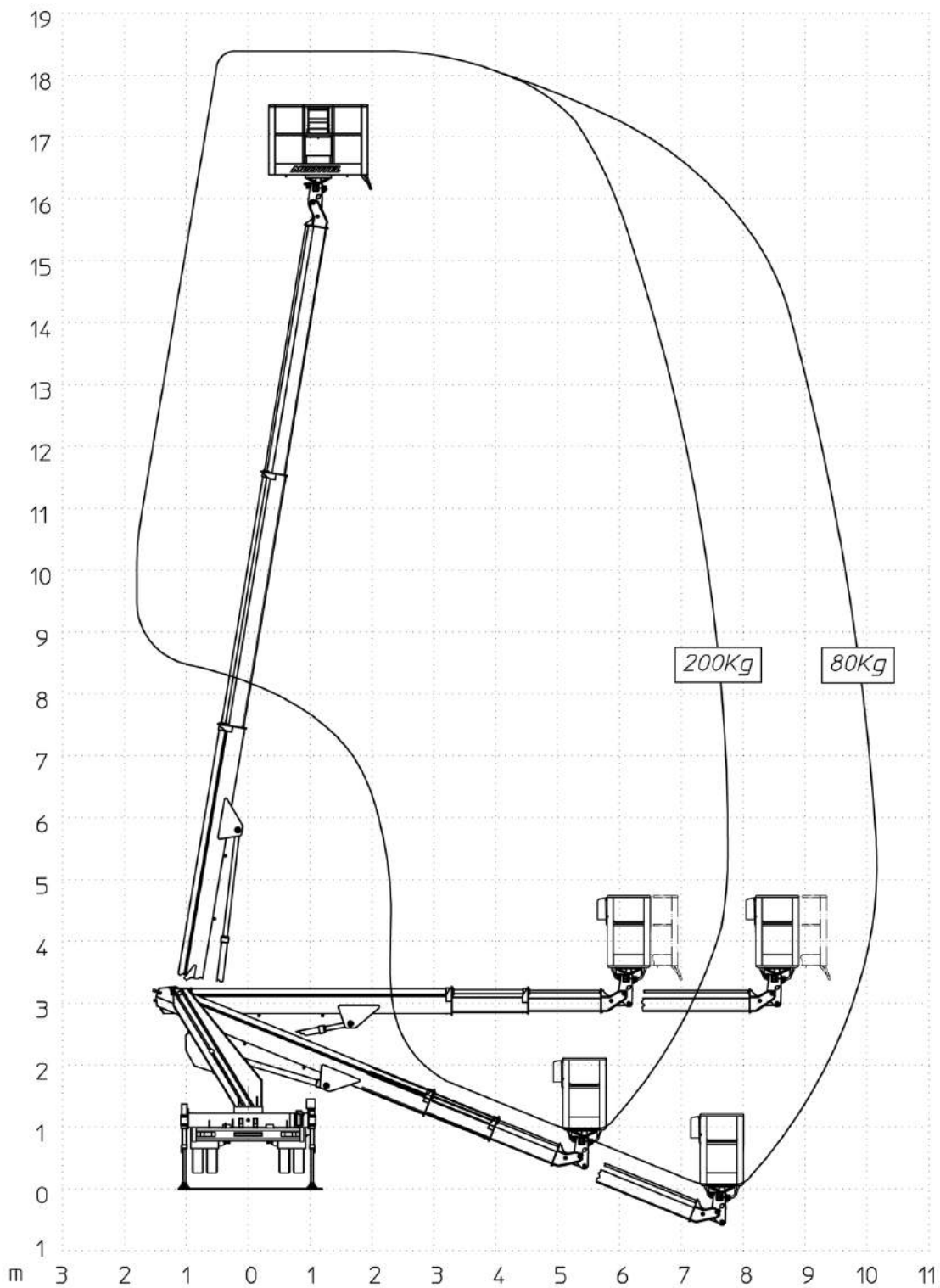

MULTITEL MT 182 EX

Sbraccio di lavoro in funzione alla stabilizzazione

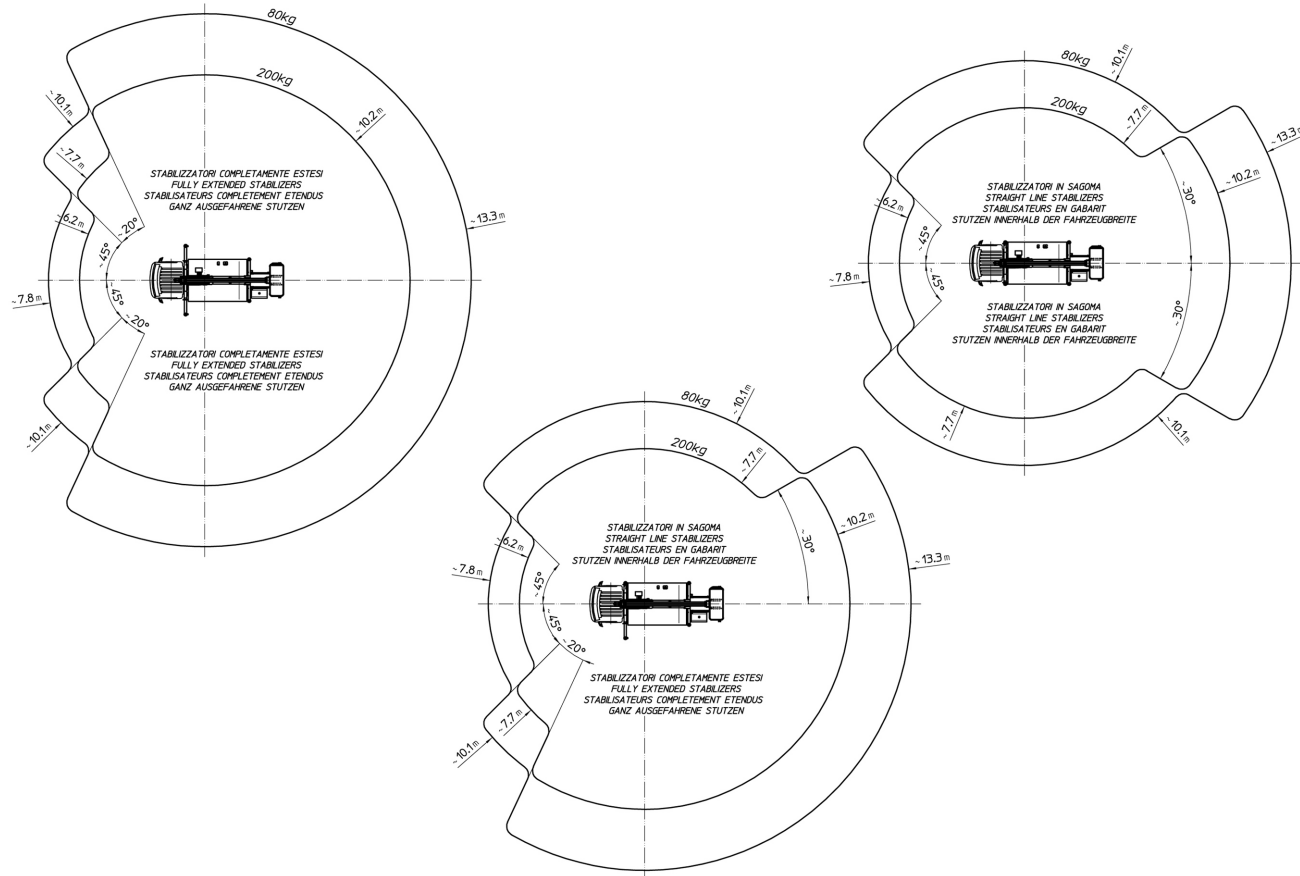

MULTITEL MT 182 EX

Nissan Cabstar

Ingombro veicolo

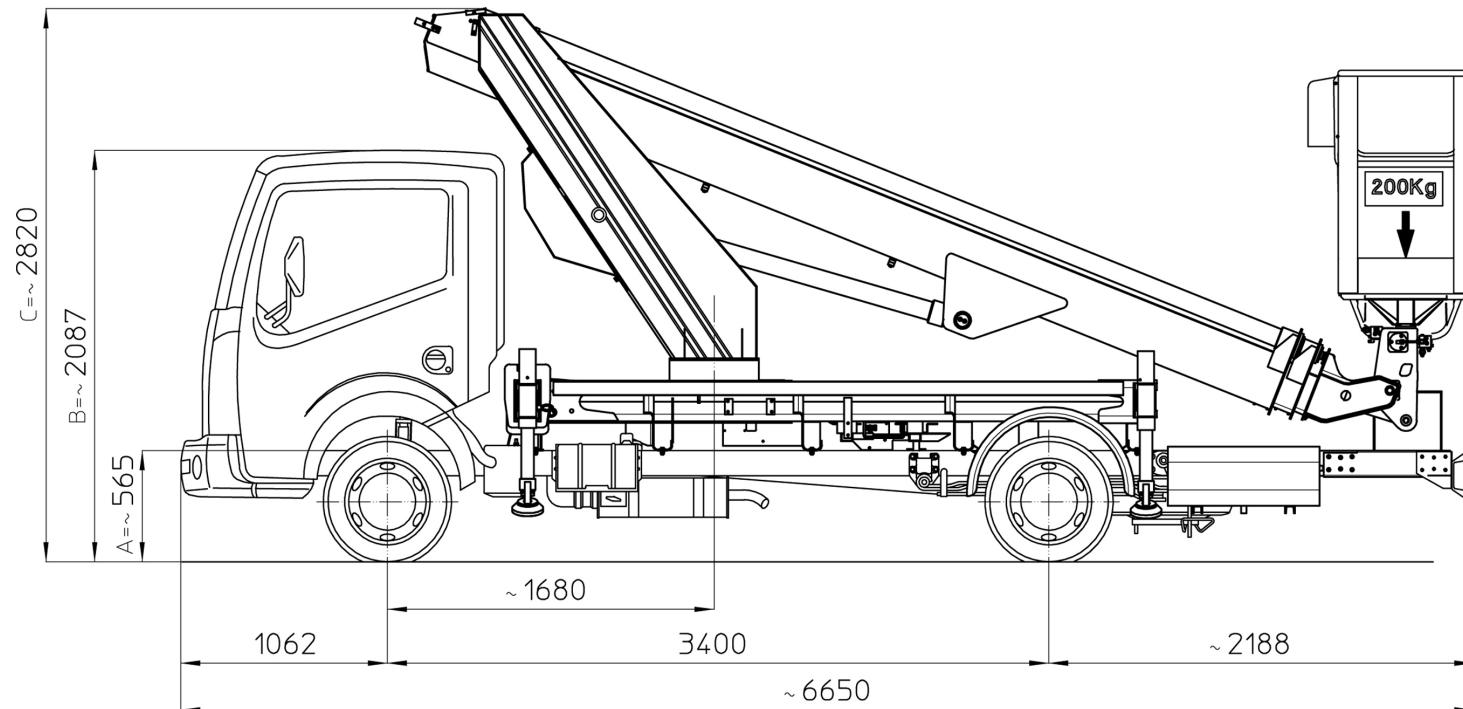

MULTITEL MT 182 EX

Ingombro stabilizzazione

